

HEAVY STAMPING

SPECIFICATIONS

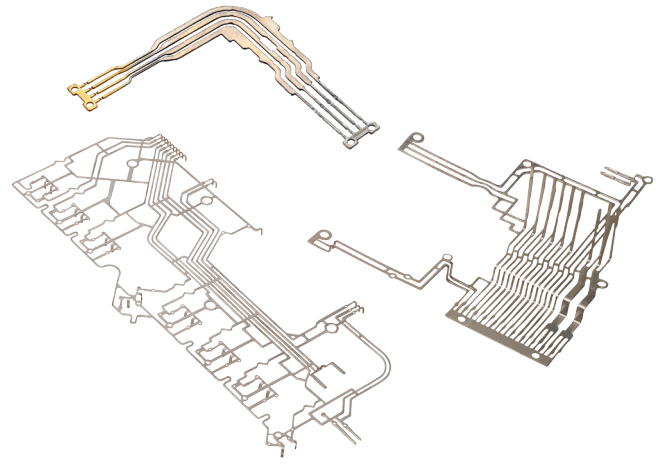

Press Rating

100 TO 450 TONS

Maximum Press Stroke

8.5 IN (215 MM)

Maximum Press Bed Width

55 IN (1,397 MM)

Part Thickness

**.008 IN (.2 MM)
TO .375 IN (9 MM)**

Press Speed

	STROKES/MIN
CONVENTIONAL PRESSES	UP TO 140
SERVO PRESSES	UP TO 250
ADJUSTABLE STROKE PRESSES	UP TO 400

Maximum Press Bed Length

120 IN (3,048 MM)

Part Length/Width or Diameter

**0.25 IN (6.35 MM)
TO 24 IN (609.6 MM)**

Tolerance

+/- .001 IN (+/- .025 MM)